

MSI-NC911

*3 Ch. Counter/timer
&
24 Bit DIO Module*

Copyright

IBM is a trademark of International Business Machines Corporation. MS-DOS, MICROSOFT C and Quick BASIC are trademarks of Microsoft Corporation. TURBO C is a trademark of Borland Inc. BASIC is a trademark of Dartmouth College. Intel is a trademark of Intel Corporation

CHECK LIST

Before getting started, check if your NC – 911 24 Bit DIO & 3Ch.

Counter/Timer Module package includes the following items:

- **NC – 911 board**
- **Screw 3mm (x 4)**
- **Bronze stick 6mm (x 4)**
- **NC – 911 User's Manual**
- **Warranty card**

If anything is missing, please contact your dealer.

Table of Contents

CHAPTER 1 INTRODUCTION	1
General Description.....	1
Applications.....	1
Features.....	2
Specifications.....	3
Accessories Guide	5
CHAPTER 2 MODULE CONFIGURATION AND INSTALLATION..	6
Component Locator Diagram.....	6
Base Address Switch	7
Interrupt Select Jumper.....	9
+12V or Ground Selection	10
Connector Pin Assignment	11
Resistor Pack	13
Hardware Description	14
Hardware Installation	14
CHAPTER 3 REGISTER STRUCTURE AND FORMAT	16
NC-911/910 I/O Address Map	16
8254 Counter Data and Control Registers	17
Digital I/O Registers	20
CHAPTER 4 PROGRAMMING	22
Programming Examples	22
APPENDIX A PC I/O PORT MAPPING	23
APPENDIX B BLOCK DIAGRAM	24
APPENDIX C TECHNICAL REFERENCE	25
General Usage of Digital Input and Output	25
NC-911/910 Port A, B and C Basic Definition	27
APPENDIX D PROGRAMMING 8254 COUNTER/TIMER	28
Introduction	28
Counter Read/Write and Control Register	28
Read-Back Command	30
Counter Operating Mode	32
Programming Counter/Timer	35
APPENDIX E PC/104 MECHANICAL SPECIFICATION	37
PC/104 General Description	37
Module Dimensions	37

CHAPTER 1 INTRODUCTION

General Description

The NC- 911/910 is a PC/104 module which is primary intended to PC embedded application in industrial environment. It contains 24 digital input/output channels and 3 counter/timer channels.

The 24-bit digital input and output are arranged to emulate 8255 PPI (Programmable Peripheral Interface) chip mode 0 but with stronger driving capability. The 24-bit DIO is further divided into three 8-bit ports (Port A, Port B and Port C) which can be functionally programmed as either digital input or digital output ports. There is a unique feature associated with NC-911/910. An external input interrupt ability. This feature frees up the PC to do other activities since there is no need to poll the digital input for an event to occur.

For timing functions, the NC-911/910 uses the popular 8254 integrate chip. The 8254 has three programmable counters and can be used as event counter, rate generator, square wave generator, frequency measurement, etc.

Applications

- Sense and control high level signals through I/O module.
- Sense low level (TTL) switches or signals.
- Drive indicator light or control recorders.
- Parallel data transfer to PC.
- Period and pulse width measurement.
- Event and frequency counting.
- Waveform and pulse generation.
- Baud rate generator.

Features

- **PC/104 standard expansion module.**
- **24 TTL/DTL digital I/O lines.**
- **24mA output drive/sink current.**
- **Easy interface to high level signals.**
- **Three 8-bit ports independently selectable for I/O.**
- **3 programmable counter/timer channels.**
- **Include timed interrupt generation.**
- **50-pin digital connector compatible with NC-951, NC-954, NC-955 or NC956 accessory board.**

Specifications

Digital I/O

Number of Channels	24
I/O Configuration	TTL/DTL compatible
Operation Mode	Emulates 8255 mode 0
Input / Output Mode	Pair
Improved Noise Margins	Hysteresis $V_{T+} - V_{T-} = 0.4(\text{typ.})$
Added Pull-up Resistor	CMOS/dry contact compatible
Digital Input	
Logic High Input Voltage	2V min
Logic Low Input Voltage	0.8V max
Logic High Input Current	20uA max. at $V_I=2.7V$
Logic Low Input Current	-0.2mA max. at $V_{IL}=0.4V$
Digital Output	
Logic High Output Voltage	2.4V min. at $I_{OH}=-3mA$
Logic Low Output Voltage	0.4V max. at $I_{OL}=12mA$
Logic High Output Current	-15mA source max.
Logic Low Output Current	24mA sink max

Programmable Counter/Timer

Type	82C54
Number of Counters	3 independent 16-bit counters
Frequency Range	DC to 10MHz
Modes	6 programmable mode
Input / Output Level	TTL, DTL, CMOS compatible

Interrupt

PC bus IRQ 9(2), 5, 10, 11, 12, 15

Source Enable control and positive trigger

Power Requirement

+5V 200mA typ

Physical/Environmental

I/O Connector 50-pin male ribbon connector
20-pin male ribbon connector

I/O Cable Type Ribbon stripline cable
($Z_0=30\ \Omega$ to $80\ \Omega$)

Dimensions 95mm * 90mm

Weight 200g

Operating Temperature 0 to 60°C

Storage Temperature -40 to 100°C

Humidity 0 to 90%, non-condensing

Accessories Guide

NC-951

Screw terminal board for all digital I/O connections. Shipped with 3.3 feet (1 meter) cable and 50-pin connector.

NC-954

24-channel opto-isolated D/I panel for signal connection and conditioning with the NC-911/910. Shipped with 3.3 feet (1 meter) cable and 50-pin connector.

NC-955

8-channel electromechanical single-pole, double-throw (SPDT) and 16-channel opto-isolated digital I/P panel which is compatible with the NC-911/910 Shipped with 3.3 feet (1meter) cable and 50-pin connector.

NC-956

24-channel electromechanical single-pole, double-throw (SPDT) which can be driven by the NC-911/910. Shipped with 3.3 feet (1 meter) cable and 50-pin connector.

Component Locator Diagram

The following figure shows the location of NC-911/910's component. All switch and jumper settings in this figure are factory default setting.

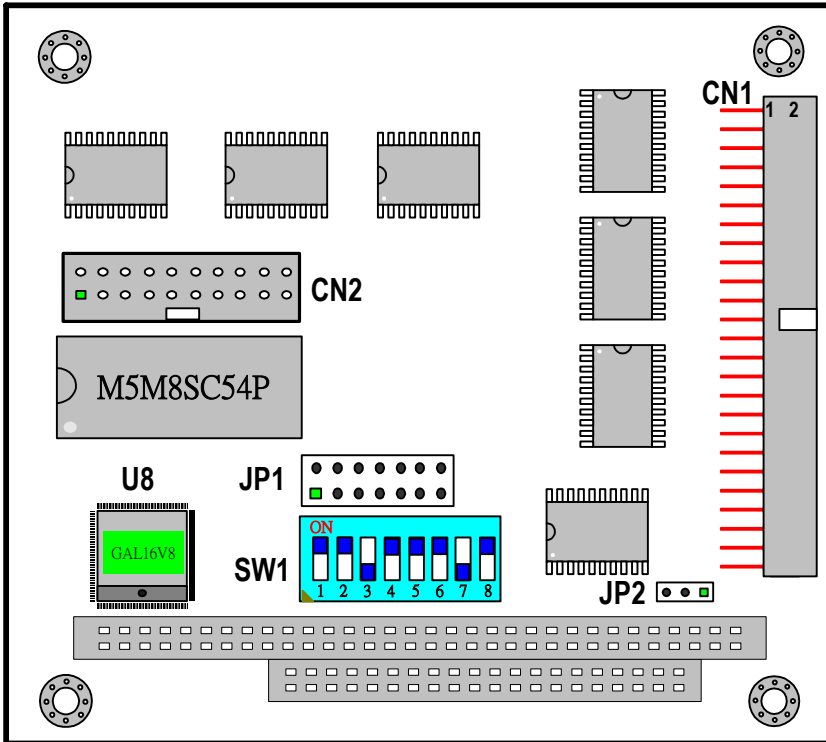

Base Address Switch

NC-911/910 occupies eight consecutive I/O port spaces. The I/O port addresses are set via a DIP switch labeled SW1. Set the DIP switch to correct address and avoid conflicting with other devices (refer to APPENDIX A for I/O port distribution). Valid addresses are from 200Hex to 3F8 Hex. Following figure is the default setting where the base address is set to 220 Hex.

To set to appropriate base address, switch the individual switches into the ON or OFF position. Figure below shows the DIP switch default setting, 220 Hex, where switches 1 and 5 are moved to the OFF position while leaving all other switches in the ON position. A table for DIP switch setting is given in the following page.

BASE ADDRESS SWITCH SETTING

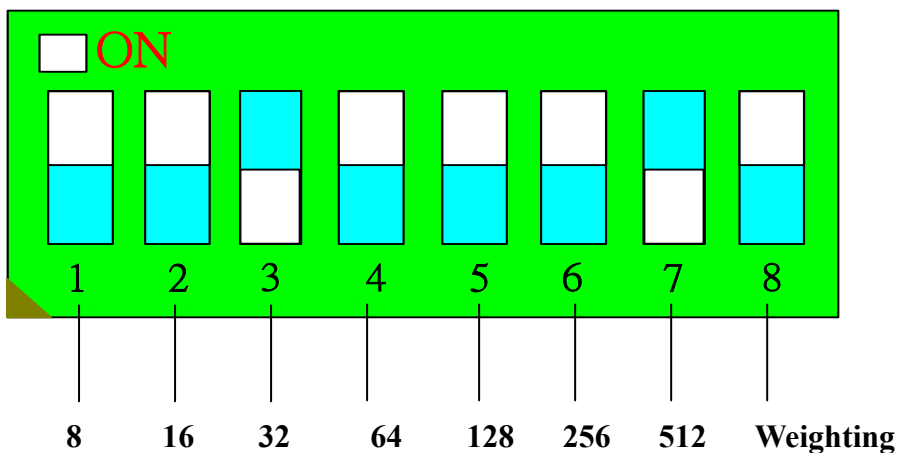

X: Not used.

$$\begin{aligned}\text{Base Address} &= 512 + 32 = 544 \text{ (Decimal)} \\ &= 220 \text{ (Hexadecimal)}\end{aligned}$$

I/O PORT RANGE	DIP SWITCH POSITION							
	1	2	3	4	5	6	7	8
	A1	A2	A3	A4	A5	A6	A7	X
200 – 207	0	0	0	0	0	0	1	X
208 – 20F	1	0	0	0	0	0	1	X
210 – 217	0	1	0	0	0	0	1	X
218 – 21F	1	1	0	0	0	0	1	X
220 – 227 (*)	0	0	1	0	0	0	1	X
·				·				
·				·				
300 – 307	0	0	0	0	0	1	1	X
·				·				
·				·				
3F0 – 3F7	0	1	1	1	1	1	1	X
3F8 – 3FF	1	1	1	1	1	1	1	X

0 = ON, **1 = OFF,** **X = don't care**
(*): Factory Default Setting

Interrupt Select Jumper

The NC-911/910 accept external inputs at INTE and INTP pins of CN2 20-pin connector. These inputs are lead to any of the six interrupt request lines (IRO level 9(2), 5, 10, 11, 12, 15) by the following jumpers

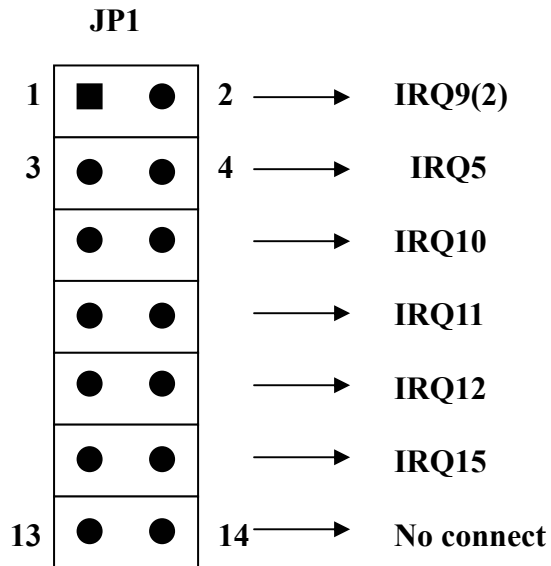

In factory jumper JP1 pin13-pin14 is installed on .

12V or Ground Selection

Pin 2 and pin 4 of CN1 (50-pin connector) can be set to output PC + 12V or Ground by setting jumper JP2. The JP2 configuration is listed in below table.

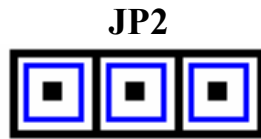

JP2 jumper configuration	<p>JP2</p> <p>1</p> <p>Factory default setting</p>	<p>JP2</p> <p>1</p>
Pin 2 and 4 at CN1 connector	Connected to Ground	Connected to +12V
CN1 compatible	NC9416, NC9424 ect.	NC-954, NC955, NC956, ect.

Jumpering PC +12V to CN1 connector allows the NC-911/910 to provide +12v power for direct relay driving voltage or input pull high voltage. Note that when using the NC-911/910 with standard Opto-22 interface panel board, pins 1 and 2 of JP2 jumper must be connected.

Connector Pin Assignment

All NC-911/910 DIO signals are built into a 50-pin connector labeled CN1 whose pin assignment are shown below. Via this connector the NC-911/910 is compatible with **NC-951**, **NC954**, **NC754**, **NC756** accessory board or standard Opto-22 interface panel.

NAME	PIN	PIN	NAME	I/O CHANNEL
Ground	50	49	+ 5V	-
Ground	48	47	PA 0	0
Ground	46	45	PA 1	1
Ground	44	43	PA 2	2
Ground	42	41	PA 3	3
Ground	40	39	PA 4	4
Ground	38	37	PA 5	5
Ground	36	35	PA 6	6
Ground	34	33	PA 7	7
Ground	32	31	PB 0	8
Ground	30	29	PB 1	9
Ground	28	27	PB 2	10
Ground	26	25	PB 3	11
Ground	24	23	PB 4	12
Ground	22	21	PB 5	13
Ground	20	19	PB 6	14
Ground	18	17	PB 7	15
Ground	16	15	PC 0	16
Ground	14	13	PC 1	17
Ground	12	11	PC 2	18
Ground	10	9	PC 3	19
Ground	8	7	PC 4	20
Ground	6	5	PC 5	21
(*)	4	3	PC 6	22
(*)	2	1	PC 7	23

+5V : + 5V PC power supply

(*) : These pins can be connected to + 12V PC power or Ground by jumpering JP2. Refer to +12V or Ground Selection section.

WARNING

As pin 2 and pin 4 of CN1 can be connected to GND or +12V, by setting JP2 jumper, thus when the NC-911/910 is connected to other card through this 50-pin connector, user must pay attention to the connector pin assignment (especially pins 2 and 4) of the corresponding card.

All input or output lines of NC-911/910 counter/timer are built into CN2 (20-pin connector). The CN2 connector pin assignments are as follows:

NAME	PIN	PIN	NAME
CLK0	1	2	+ 12V
G0	3	4	GND
OUT0	5	6	GND
CLK1	7	8	GND
G1	9	10	10MHz
OUT1	11	12	GND
CLK2	13	14	INTP
G2	15	16	INTE
OUT2	17	18	GND
N/C	19	20	+ 5V

- CLK0 – CLK2 : Clock input to 8254 counter 0 through 2
- +12V : +12V PC power
- G0 – G2 : Gate control input to 8254 counter 0 through 2
- GND : Ground
- OUT0 – OUT2 : Output from 8254 counter 0 through 2
- 10MHz : 10MHz frequency output
- INTP : Interrupt trigger input
- INTE : Interrupt enable input
- N / C : No connect
- +5V : +5V PC power

Resistor Pack

As mentioned before the 8-bit port digital I/O lines can be configured as input or output port (refer to Chapter 3). Initially the digital I/O lines are left floating. When any of these ports is set to input port, user is suggested to pull high it's input lines by installing RP(s). Onboard there are 3 reserved spaces, marked as RP1-RP3 (refer to table below, the RP is approximately 4.7k).

If a port is configured as output lines, just leave the corresponding RP unoccupied.

If CN1 is connected to **NC9416 and NC9424**, the RP should be installed to prevent power-on floating phenomenon. This floating may cause SSR to action (switch on).

DIO Lines	RP
Port A	RP3
Port B	RP2
Port C	RP1

NOTE:

In some situations, i.e. environment ground is not stable, the digital output reset frequently. User is suggested to isolate system circuitry from external signal. Let the external signal to go through **NC-954 (24 channel opto-isolated D/O panel) or NC955 (8 channel relay output and 16 channel opto-isolated D/I panel) or NC956 (24 channel relay output) before reaching the system circuitry.**

Hardware Description

PC/104 module can be of two bus types, 8 bit and 16 bit. These correspond to the PC and PC/AT buses, respectively. The detailed mechanical dimensions of these two PC/104 bus types are provided in APPENDIX E PC/104 MECHANICAL SPECIFICATIONS.

Basically the NC-911/910 belongs to 16 bit bus option which is designed only to by pass PC/AT bus signal in order to compatible to PC/AT type PC/104 module. The NC-911/910 use only IRQ lines on P2 40-pin connector. If this module is going to plug onto PC type PC/104 bus, do not use IRQ line above 10.

Beside bus option, there are stack through and non-stack through difference. The stack through version provides a self-stacking PC bus. It can be placed any where in a multi-module stack. The non-stack through version offers minimum thickness, by omitting bus stack through pins. It must be positioned at one end of a stack.

For convenience, the NC-911/910 is equipped with stack through version only. (NOTE: For safety, you are suggested to cut bus stack through pins of the last module on condition; that you are sure you won't add/plug any module to the module stack in the future.)

Hardware Installation

The NC-911/910 PC/104 module is shipped with protective electrostatic cover. When unpacking, touching the module electrostatically shielded packaging with the metal frame of your computer to discharge the accumulated static electricity prior to touching the module.

Following description summarizes the procedures for installing the NC-911/910.

WARNING

TURN OFF the PC and all accessories connected to the PC whenever installing or removing any peripheral board including the NC-911/910 module.

Installation procedures:

- 1. Turn off the system power.**
- 2. Unplug all power cords.**
- 3. Remove the case cover if necessary.**
- 4. Remove the top module if it a non-stackthrough module.**
- 5. Put the NC-911/910 module in line with the top present module as described in APPENDIX E PC/104 MECHANICAL SPECIFICATION.**
- 6. Install four spacers if necessary.**
- 7. Connect cable to CN2 if necessary.**
- 8. Crush between the module until inside distance is SPACER's height (0.6"). Restore all the screws.**
- 9. Repeat step 6 until all module are set into position.**
- 10. Connect cable (CN1) to CN-911/910 if necessary.**
- 11. Replace the case cover and connect all the necessary cables.**
- 12. Turn on the system power.**

CHAPTER 3 REGISTER STRUCTURE AND FORMAT

NC-911/910 I/O Address Map

This chapter describes each NC-911/910 register in terms of function, address, bit structure and bit function. Each register is easy to read and write to by using direct I/O instructions of whatever application languages.

NC-911/910 uses 8 consecutive addresses in I/O space as follows (R= Read, W= Write):

Location	Function	Type
Base address + 0	Counter 0	R/W
+1	Counter 1	R/W
+2	Counter 2	R/W
+3	Control Word	W
+4	Port A	R/W
+5	Port B	R/W
+6	Port C	R/W
+7	Control Register	W

8254 Counter Data and Control Registers

Counter 0 Data Register (Base +0, R/W)

base	7	6	5	4	3	2	1	0
+0	B7	B6	B5	B4	B3	B2	B1	B0

Counter 1 Data Register (Base +1, R/W)

base	7	6	5	4	3	2	1	0
+1	B7	B6	B5	B4	B3	B2	B1	B0

Counter 2 Data Register (Base +2, R/W)

base	7	6	5	4	3	2	1	0
+2	B7	B6	B5	B4	B3	B2	B1	B0

Counter Word Register (Base +3, W)

base	7	6	5	4	3	2	1	0
+3	SC1	SC0	RW1	RW0	M2	M1	M0	BCD

Where SC – Counter

SC1	SC0	Description
0	0	Select Counter 0
0	1	Select Counter 1
1	0	Select Counter 2
1	1	Read-back

Where RW – Read/Write

RW1	RW0	Description
0	0	Counter latch command
0	1	R/W LSB only
1	0	R/W MSB only
1	1	R/W LSB first, then MSB

Where M – Mode

M2	M1	M0	Description
0	0	0	Mode 0 : Pulse on terminal count
0	0	1	Mode 1 : Programmable one-shot
X	1	0	Mode 2 : Rate generator
X	1	1	Mode 3 : Square wave mode
1	0	0	Mode 4 ; Software triggered mode
1	0	1	Mode 5 : Hardware triggered strobe

BCD – Binary Coded Decimal:

BCD	Description
0	Binary counter 16 - bit
1	Binary coded decimal (BCD)counter (4 decodes)

NOTE:

This module uses 8254 integrate chip for its programmable counter/timer channels. Refer to APPENDIX D PROGRAMMING 8254 COUNTER/TIMER or the 8254 Data Book for detailed information.

Digital I/O Registers

The 24 digital I/O lines of NC-911/910 are arranged into one group. This group emulates 8255 PPI chip mode 0 and is further divided into three ports; Port A, Port B and Port C

The NC-911/910 is programmable through the configuration registers. By writing to control registers, the I/O direction of each port may be specified. If a port is configured as a write (output) port, the data drives will drive the data value to the corresponding port. If a port is configured as a read (input) port, the data value on corresponding port will be sent to the digital I/O lines.

Only port C is different from the other two ports, that is Port C consists of two 4-bit ports, Port C-upper and C-lower, which can separately be configured as input or output port.

Port A Data Register (Base +4, R/W)

base	7	6	5	4	3	2	1	0
+4	PA7	PA6	PA5	PA4	PA3	PA2	PA1	PA0

Port B Data Register (Base +5, R/W)

base	7	6	5	4	3	2	1	0
+5	PB7	PB6	PB5	PB4	PB3	PB2	PB1	PB0

Port C Data Register (Base +6, R/W)

base	7	6	5	4	3	2	1	0
+6	PC7	PC6	PC5	PC4	PC3	PC2	PC1	PC0

PC0 – PC3 : Port C – lower Byte
PC4 – PC7 ; Port C – upper Byte

Control Register (Base + 7, W)

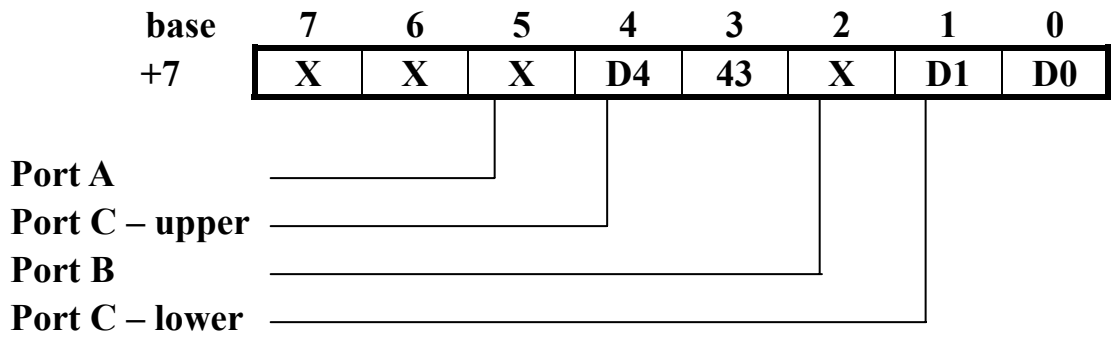

NOTE:

PA0 – PA7, PB0 – PB7 and PC0 – PC7 bits are associated to pins at CN1 connector.

X = don't care

For D0, D1, D3, D4 : 1 → Input, 0 → Output

CHAPTER 4 PROGRAMMING

NC-911/910 provides 24 bit digital I/O which are divided into three 8-bit ports (A, B and C). Port C is divided into two 4-bit nibbles; Port C- upper and C- lower. The I/O direction of the ports (Port A, B, C-upper and C-lower) can be determined by programming to the control register.

Programming Examples

The following BASIC program configures Port A and B as input port (install corresponding RP's if necessary), Port C as output port. An increasing pattern is sent to Port C. It is expected that user will connect both Port A and Port B to Port C before running this program.

```
10 CLS
20 PORT% = &H220      'REM Base Address
30 OUT PORT% + 7, &H92 'REM Port A, B: input, Port C: output
40 FOR C = 0 to 255   'REM decimal value form 00 to FF
50 OUT PORT% + 6, C   'REM output data to Port C
60 A = INP (PORT% + 4) 'REM read data on Port A
70 B = INP (PORT% + 5) 'REM read data on Port B
80 PRINT A, B, C      'REM check data versus Port A and B
90 NEXT C
100 END
```

APPENDIX A PC I/O PORT MAPPING

I/O Port Address Range	Function
000 – 1FF	PC reserved
200 – 20F	Game controller (Joystick)
278 – 27F	Second parallel print port (LPT2)
2E1	GPIB controller
2F8 – 2FF	Second serial port (COM2)
320 – 32F	Fixed disk (XT)
378 – 37F	Primary parallel print port (LPT1)
380 – 38F	SDLC communication port
3B0 – 3BF	Monochrome adapter/printer
3C0 – 3CF	EGA, reserved
3D0 – 3DF	Color/graphics adapter
3F0 – 3F7	Floppy disk controller
3F8 – 3FF	Primary serial port (COM1)

APPENDIX B BLOCK DIAGRAM

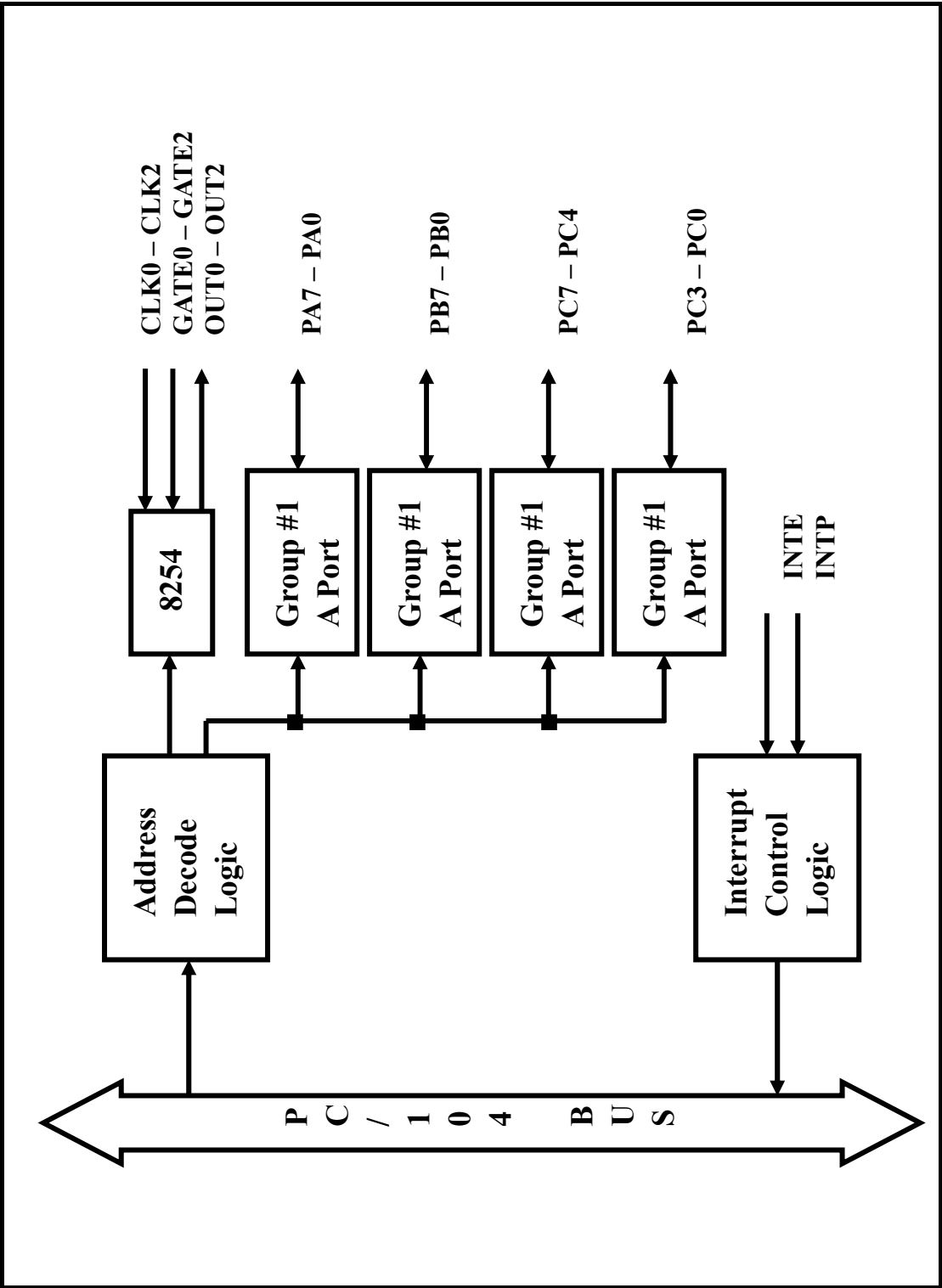

APPENDIX C TECHNICAL REFERENCE

General Usage of Digital Input and Output

Digital signals are usually used for detecting logical status or controlling devices, a brief description is given below. TTL level signals are developed by most DAS systems.

TTL or LSTTL Level I/O Connections

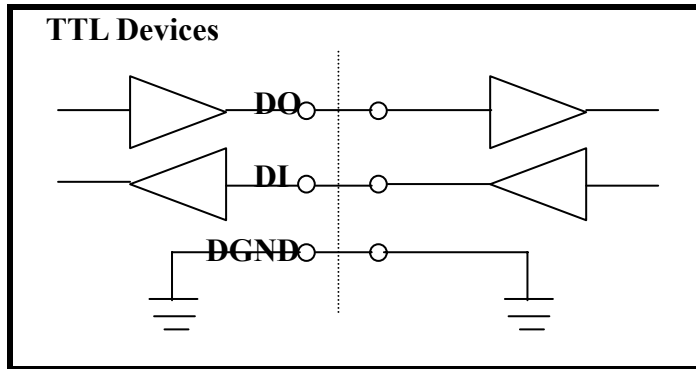

Connection with COMS Device – Use a pull-up resistor if you wish to interface to COMS devices. This will raise the logic high output level from its minimum TTL level of 2.4 to +5V suitable for COMS interface.

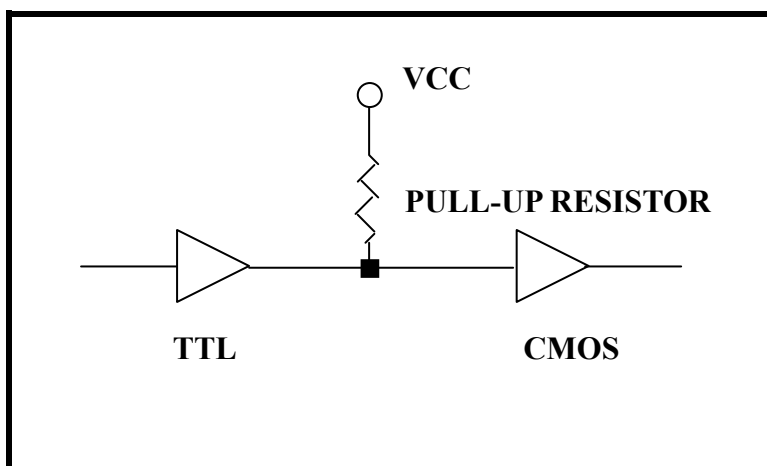

Digital Input for Open / Short Switch Detection – A pull-up resistor must be connected, especially at long distance wiring, to ensure logic high input level.

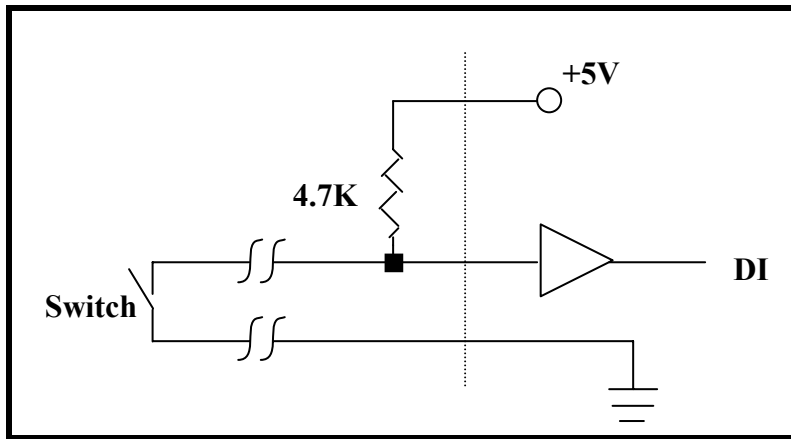

Digital Input for Large Signal

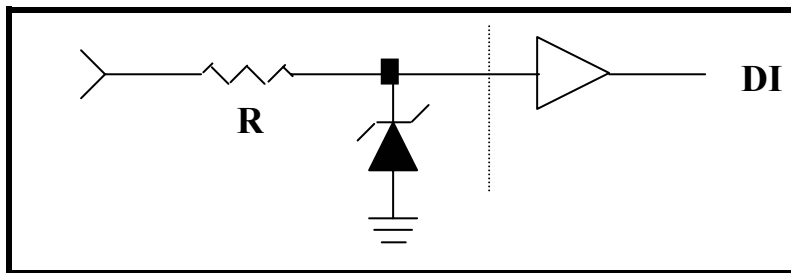

Digital Output for Relay Driving – The D1 diode is added to protect the IC driver against the inductive “kickback” from the relay coil.

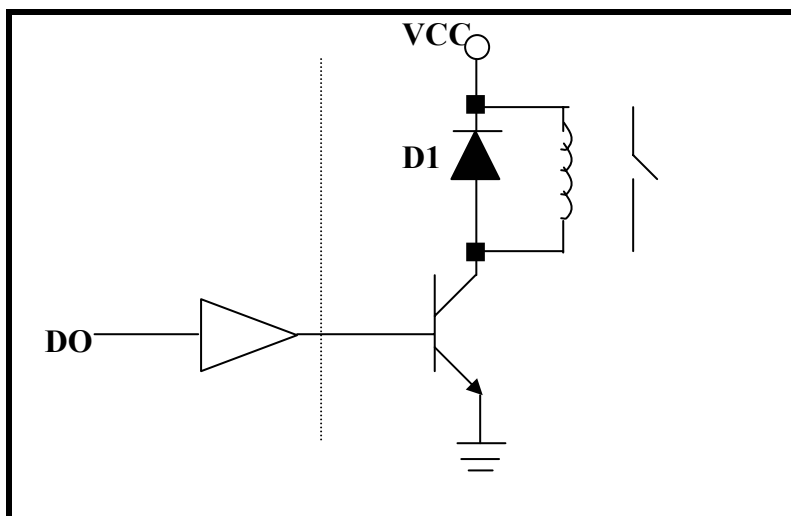

NC-911/910 Port A, B and C Basic Definition

(1) Equivalent ckt of port A, B and C

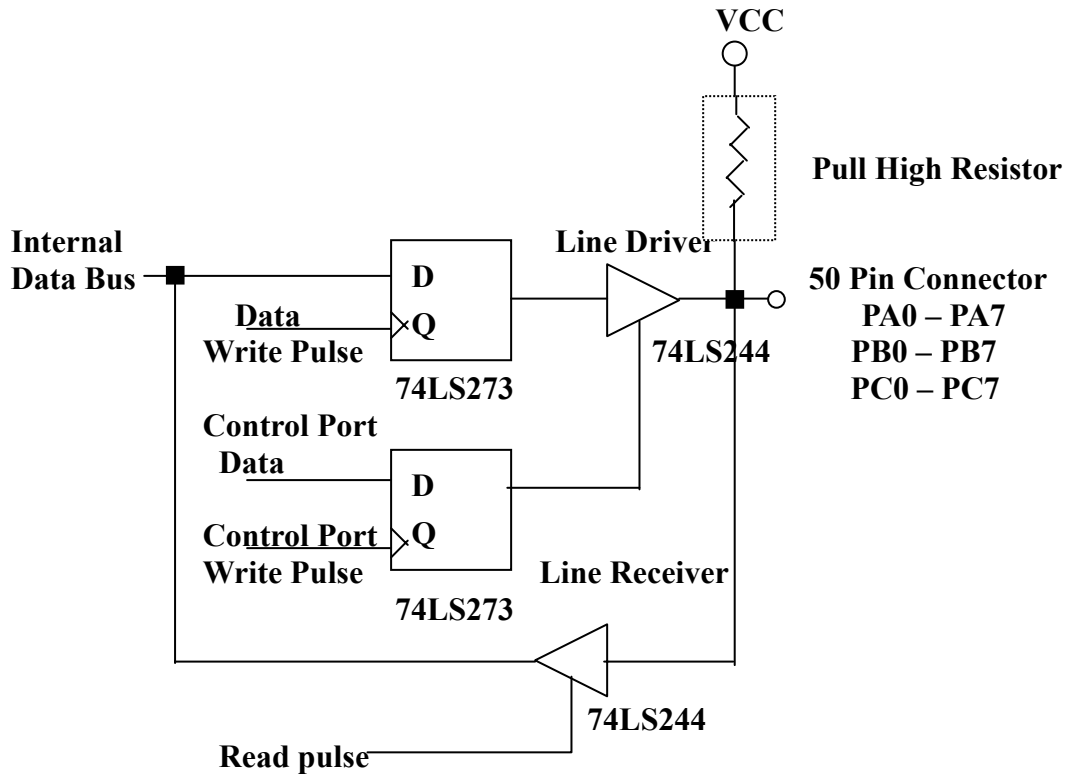

NOTE:



- (2) Any port is programmable to input or output.
- (3) Outputs are driven by 74LS244 and latched by 74LS273.
- (4) Inputs are received by 74LS244 but not latched.
- (5) All inputs and outputs are buffered by standard line drives and line receivers.
- (6) The initial state and default setting of port A, B and C are tri-state.

APPENDIX D PROGRAMMING 8254 COUNTER/TIMER

Introduction

AXIOM's NC-911/910 module uses INTEL 8254 which consist of three independently programmable 16-bit counters for its timing function. Each counter can be programmed to be divided by number within the range of 2 – 65535. The 8254 is suitable for:

- Event counter
- Delay time generator
- Programmable one-shot
- Square wave generator

For detailed information, user should refer to the 8254 Programmable Interval Timer data sheet.

Counter Read/Write and Control Register

There are 4 registers needed to program 8254 Time/Counter, including three Read/Write and one Control register as follows:

Base +0 through Base +3:

Base +0	Counter 0	Read/Write register
Base +1	Counter 1	Read/Write register
Base +2	Counter 2	Read/Write register
Base +3	Control word	register

Read/Write register is used to load divisor to select counter, or Read count from selected counter.

Control register is used to determine counter's operation.

Control Word Format

Addr . base +3

D7	D6	D5	D4	D3	D2	D1	D0
SC1	SC0	RW1	RW0	M2	M1	M0	BDC

SC – Select Counter :

SC1	SC0	
0	0	Select Counter 0
0	1	Select Counter 1
1	0	Select Counter 2
1	1	Read- Back Command (see read operations)

M – Mode :

M2	M1	M0	
0	0	0	Mode0
0	0	1	Mode1
X	1	0	Mode2
X	1	1	Mode3
1	0	0	Mode4
1	0	1	Mode5

RW – Read/Write :

RW1	RW0	
0	0	Counter Latch Command (see read operation)
0	1	Read/Write least significant byte only.
	0	Read/Write most significant byte
1	1	Read/Write least significant byte first, then most significant byte

BCD – Binary Coded Decimal

0	Binary Counter 16-bits
1	Binary Coded decimal (BCD) (4 Decades)

NOTE: Don't care bits (X) should be 0 to insure compatibility with future products.

Read- Back Command

The read-back command allows the user to check the count value, programmed Mode, and current state of the OUT pin and Null Count flag of the selected counter(s).

The command is written into the Control Word Register and has the format shown in the preceding page. The command applies to the counter selected by setting their corresponding bits D3, D2, D1 = 1.

Base Addr . +3							
D7	D6	D5	D4	D3	D2	D1	D0
1	1	COUNT	STATUS	CNT 2	CNT 1	CNT 0	0

D5: 0 = Latch count of selected Counters(s)
D4: 0 = Latch status of selected Counters(s)
D3: 1 = Select Counter 2
D2: 1 = Select Counter 1
D1: 1 = Select Counter 0
D0: Reserved for future expansion, Must be 0

Here is an example for read-back command:

COMMAND								DESCRIPTION	RESULT
D7	D6	D5	D4	D3	D2	D1	D0		
1	1	0	0	0	0	1	0	Read back count and status of Counter 0	Count and status latched for Counter 0
1	1	1	0	0	1	0	0	Read back status of Counter 1	Count latched for Counter 1
1	1	1	0	1	1	0	0	Read back status of Counter 2 and 1	Status latched for Counter 2, but not Counter 1
1	1	0	1	1	0	0	0	Read back count of Counter 2	Count latched for Counter 2
1	1	0	0	0	1	0	0	Read back count and status of Counter 1	Count latched for Counter 1, but not status
1	1	1	0	0	0	1	0	Read back status of Counter 1	Command ignored status already latched for Counter 1

Counter Operating Mode

Mode 0 : Interrupt on Terminal Count

Mode 0 is typically used for event counting. After the Control Word is written, OUT is initially low, and will remain low until the Counter reaches Zero. OUT then goes high and remains high until a new count or a new Mode 0 Control Word is written to the Counter

.

**GATE = 1 enables counting; GATE = 0 disables counting.
GATE has no effect on OUT.**

After the Control Word and initial count are written to a Counter, the initial count will be loaded on the next CLK pulse. This CLK pulse does not decrement the count, so for an initial count of N, OUT does not go high until N + 1 CLK pulses after the initial count is written

If a new count is written to the Counter it will be loaded on the next CLK pulse and counting will continue from the new count

If a two-byte count is written, the following happens:

- Writing the first byte disables counting. Out is set low immediately (no clock pulse required)
- Writing the second byte allows the new count to be loaded on next CLK pulse.

Mode 1: Hardware Retriggerable One-Shot

OUT will be initial high. OUT will go low on the CLK pulse following a trigger to begin the one-shot pulse, and will remain low until the Counter reaches zero. OUT will then go high and remain high until the CLK pulse after the next trigger.

After writing the Control Word and initial count, the Counter is armed. A trigger results in loading the Counter and setting OUT low on the next CLK pules, thus starting the one-shot pulse N CLK cycles in duration. The one-short pulse can be repeated without rewriting the same count into the counter. GATE has no effect on OUT.

If a new count is written to the Counter during a one-short pulse, the current one-shot is not affected unless the Counter is retriggered. In that case, the Counter is loaded with the new count and the one-shot pulse continues until the new count expires.

Mode 2: Rate Generator

This Mode functions like a divide-by-N counter. It is typically used to generate Real Time Clock interrupt. OUT will initial be high. When the initial count has decremented to 1, OUT goes low for one CLK pulse. OUT the goes high again, the Counter reloads the initial count and the process is repeated Mode 2 is periodic; the same sequence is repeated indefinitely. For an initial count of N, the sequence repeats every N CLK cycles.

After writing a Control Word and initial count, the Counter will be loaded on the next CLK pulse. OUT goes low N CLK pulses after the initial count is written. This allows the Counter to be synchronized by software also

Mode 3: Square Wave Mode

Mode 3 is typically used for Baud rate generation. Mod 3 is similar to Mode 2 except for the duty cycle of OUT. OUT will initial be high. When half the initial count has expired, OUT goes low for the remainder of the count. Mode 3 is periodic; the sequence above is repeated indefinitely. An initial count of N results in a square wave with a period of N CLK cycles.

After writing a Control Word and initial count, the Counter will be loaded on the next CLK pulse. This allows the Counter to be synchronized by software also.

Mode 3 is implemented as follows:

EVEN COUNTS: OUT is initial high. The initial count is loaded on one CLK pulse and then is decrement by two on succeeding CLK pulses. When the count expires, OUT changes value and the Counter is reloaded with the initial count. The above process is repeated indefinitely.

ODD COUNTS: OUT is initial high. The initial count is loaded on one CLK pulse, decremented by one on the next CLK pulse, and then decremented by two on succeeding CLK pulses. When the count expires, OUT goes low and the Counter is reloaded with the initial count. The count is decremented by three on the next CLK pulse, and then by two on succeeding CLK pulses. When the count expires, OUT goes high again and the Counter is reloaded with the initial count. The above process is repeated indefinitely. So for odd counts, OUT will be high for $(N + 1)/2$ counts and low for $(N - 1)/2$ counts.

Mode 4: Software Triggered Mode

OUT will be initial high. When the initial count expires, OUT will go low for one CLK pulse the go high again. The counting sequence is “Triggered” by writing the initial count.

After writing a Control Word and initial count, the Counter will be loaded on the next CLK pulse. This CLK pulse does not decrement the count, so for an initial count of N, OUT does not strobe low until $N + 1$ CLK pulses after the initial count is written.

If a new count is written during counting, it will be loaded on the next CLK pulse and counting will counting form the new count.

If a two-byte count is written, the following happens:

- **Writing the first byte has no effect on counting.**
- **Writing the second byte allows the new count to be loaded on the next CLK pulse.**

This allows the sequence to be “retriggered” by software OUT strobes low $N + 1$ CLK pulses after the new count of N is written.

Mode 5: Hardware Triggered Strobe (Retriggerable)

OUT will initial be high. Counting is triggered by a rising edge of GATE. When the initial count has expired, OUT will go low for one CLK pulse and then go high again.

Programming Counter/Timer

Programming Sequence:

1. Writing control word to select counter and determine operation.
2. Program selected counter's LSB of R/W register.
3. Program selected counter's MSB of R/W register.

Addr . Base +			Addr. Base +		
Control Word	- Counter 0	3	Control Word	- Counter 2	3
LSB of count	- Counter 0	0	Control Word	- Counter 1	3
MSB of count	- Counter 0	0	Control Word	- Counter 0	3
Control Word	- Counter 1	3	LSB of count	- Counter 2	2
LSB of count	- Counter 1	1	MSB of count	- Counter 2	2
MSB of count	- Counter 1	1	LSB of count	- Counter 1	1
Control Word	- Counter 2	3	MSB of count	- Counter 1	1
LSB of count	- Counter 2	2	LSB of count	- Counter 0	0
MSB of count	- Counter 2	2	MSB of count	- Counter 0	0
Control Word	- Counter 0	3	Control Word	- Counter 1	3
Control Word	- Counter 1	3	Control Word	- Counter 0	3
Control Word	- Counter 2	3	LSB of count	- Counter 1	1
LSB of count	- Counter 2	2	Control Word	- Counter 2	3
LSB of count	- Counter 1	1	LSB of count	- Counter 0	0
LSB of count	- Counter 0	0	MSB of count	- Counter 1	1
LSB of count	- Counter 0	0	LSB of count	- Counter 2	2
MSB of count	- Counter 1	1	MSB of count	- Counter 0	0
MSB of count	- Counter 2	2	MSB of count	- Counter 2	2

NOTE: In all four examples, all counters are programmed to Read/Write two-byte count is. These are only four of many possible programming sequences.

Simple programming examples written in BASIC are given as follow:

Example 1 Program counter 0 as rate generator

```
10 Divisor % = 100
20 LSB % = Divisor % MOD 256
30 MSB % = Divisor % \ 256
40 Base % = & H220
50 OUT Base % + 3, & H34      'Counter 0: rate generator
60 OUT Base % + 0, LSB %    'Write low byte to counter 0
70 OUT Base % + 0, MSB %    'Write high byte to counter 0
```

Example 2 Read count of counter 0

```
10 Bas % = & H220
20 OUT Base % + 3, 0        'Latch counter 0
30 LSB % = inp (Base % + 0) 'Read low byte from counter 0
40 MSB% = inp(Base % + 0)  'Read high byte from counter 0
50 Count % = LSB% + MSB% * 256 'Read count from counter 0
```

APPENDIX E PC/104 MECHANICAL SPECIFICATION

PC/104 General Description

While the PC and PC/AT architectures have become extremely popular in both general purpose (desktop) and dedicated (non-desktop) applications, its use in embedded microcomputer applications has been limited due to the large size of standard PC and PC/AT motherboard and expansion cards.

This document supplies the mechanical and electrical specifications for a compact version of the PC/AT bus, optimized for the unique requirements of embedded systems applications. The specification is herein referred to as “PC/104”, based on the 104 signal contacts on the two bus connectors (64 pin on P1 plus 40 pins on P2)

Module Dimensions

PC/104 modules can be of two bus types, 8-bit and 16-bit. These correspond to the PC and PC/AT buses, respectively.